







# SCRAILS<sup>®</sup> FAUSSES VIS

## SCRAIL FASCOAT

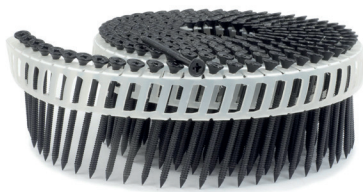
### ■ Technical description

Code	Designation			kg / 
<b>FasCoat - TX</b>				
16S2550FSB	Scrail® 25/28 x 50 <b>black</b>	2 000	96 000	221
16S2550FSR	Scrail® 25/28 x 50 <b>red</b>	2 000	96 000	221



Code	Designation			kg / 
<b>FasCoat - PH</b>				
3425050FSB	Scrail® 34° 2,5 x 50 <b>black</b>	2 200	165 000	413
3425050FSR	Scrail® 34° 2,5 x 50 <b>red</b>	2 200	165 000	413



### SCRAIL

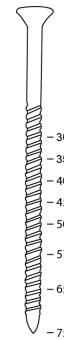

FC

### Related product



Pneumatic nailer  
C 28/50 P1  
Code : **105C2850H**



Pneumatic nailer  
C 38/90 P1  
Code : **12C3890**



Pneumatic nailer  
BOIS HN 90 F  
Code : **HN90F**

More information on  
our website:





## Coils nails

COILS 16°	DRIVE	CODE	Ød1	Ød2	ØD	L	LG	X	NAILS PER COIL
Scrail® 25/28 x 50 <b>black</b>	TORX 15	16S2550FSB	2,50	2,75	6,80	50,0	35,0	20	200
Scrail® 25/28 x 50 <b>red</b>	TORX 15	16S2550FSR	2,50	2,75	6,80	50,0	35,0	20	200

The thickness of the anti-corrosion treatment is not included.

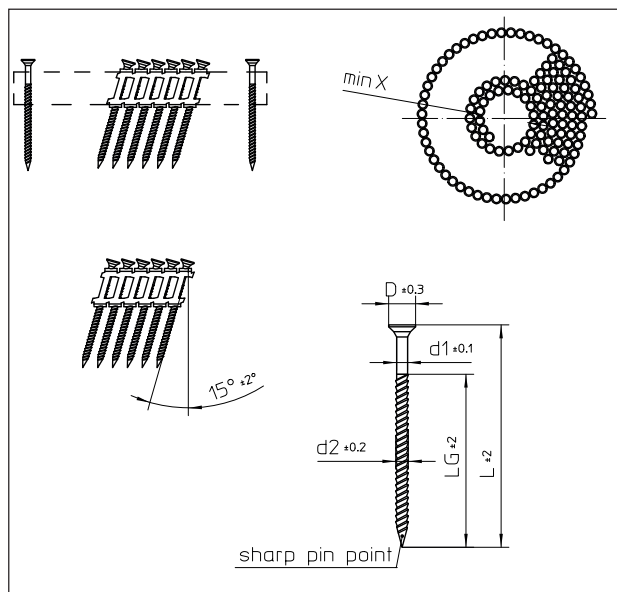

MATERIAL	
T/S min.	1300 N/mm <sup>2</sup>
Coating	FasCoat

## Strips nails

	DRIVE	CODE	Ød1	Ød2	ØD	L	LG	A	B	Y	X
Scrail® 25/28 x 50 <b>black</b>	TORX 15	3425050FSB	2,50	2,75	6,80	50,0	35,0	23	34	34	25
Scrail® 25/28 x 50 <b>red</b>	TORX 15	3425050FSR	2,50	2,75	6,80	50,0	35,0	23	34	34	25

The thickness of the anti-corrosion treatment is not included.

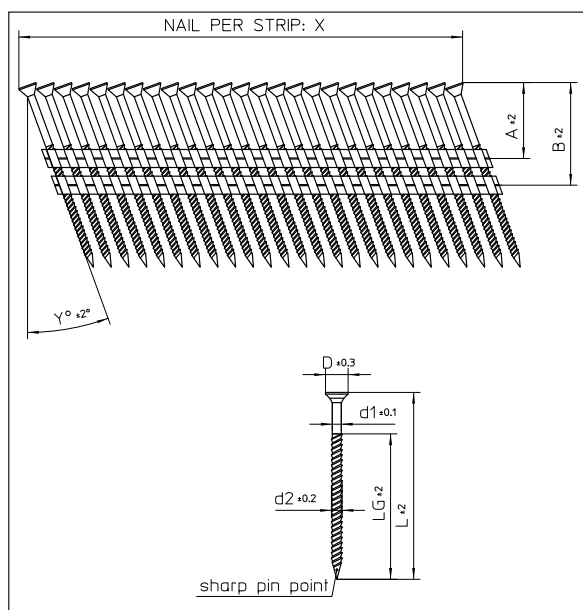

MATERIAL	
T/S min.	1300 N/mm <sup>2</sup>
Coating	FasCoat

All information is subject to change without notice and Alsafix cannot be held responsible for installation without prior calculation and testing.